

MABEF

M.A.B.E.F. srl

Via A.Volta, 77/79
21010 Cardano al Campo
(Varese) - Italy
Tel. +39/0331/261.651
Fax +39/0331/262.249

http://www.mabef.it
E-mail: support@mabef.it

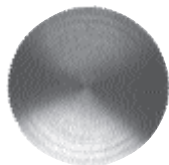

BREVETTO N.1183733

PATENT N.1183733

M/30

M/30 CAVALLETTI DA
STUDIO
M/30 STUDIO EASELS
M/30 M/3

MABEF

1	asta laterale destra right side leg	A	n.1 mm.4	
2	asta laterale sinistra left side leg	H	n.5 mm.7x50	
3	traversa inferiore lower crossbar	F	n.4 mm.6x50	
4	traversa superiore upper crossbar	X	n.4 mm.6x60	
5	piano lavoro working table	B	n.4 mm.10x20x6	
6	asta centrale scorrevole top canvas holder	W	n.1 mm. 6x30	
7	cassetta portatela lower canvas holder	U	n.4 mm.6x24	
8	cassettiera a 3 cassetti 3 drawers chest	P	n.4 mm.45	
9	cassettiera a 1 cassetto 1 drawer chest			

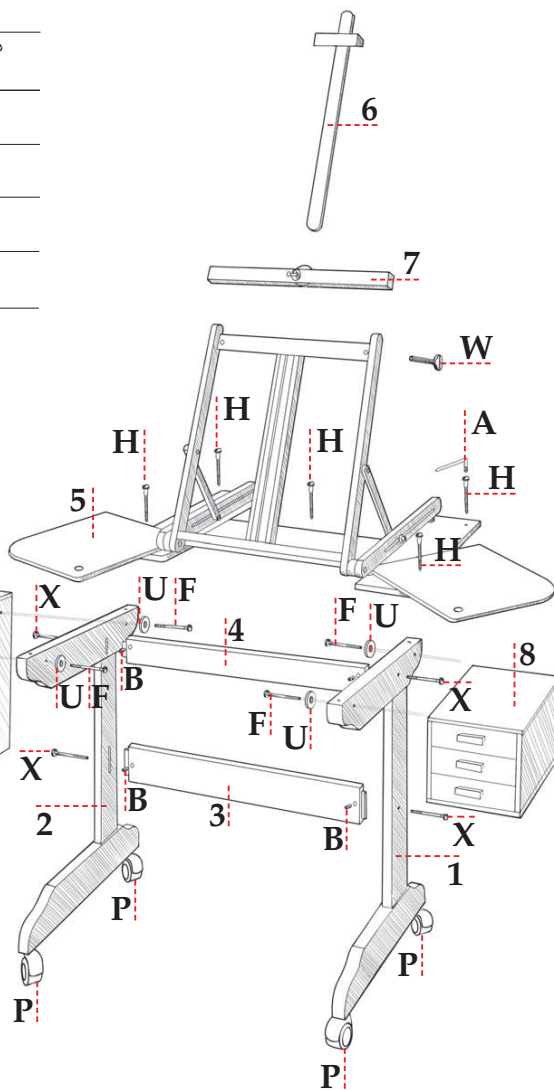

MABEF

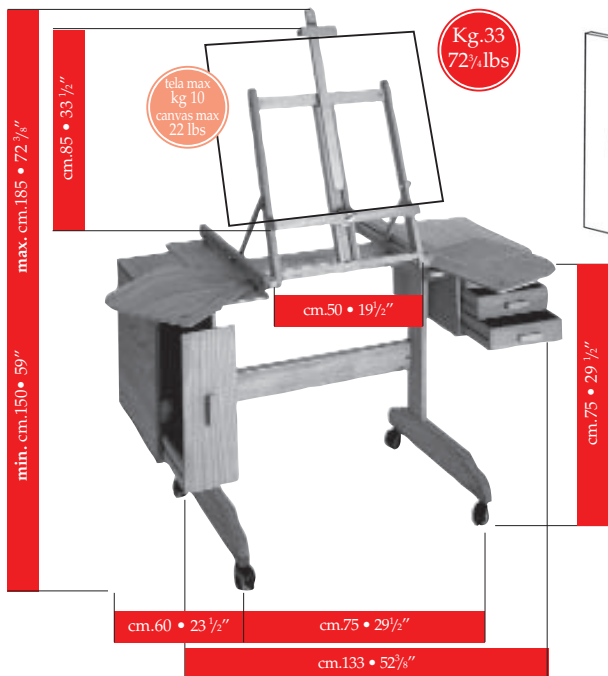

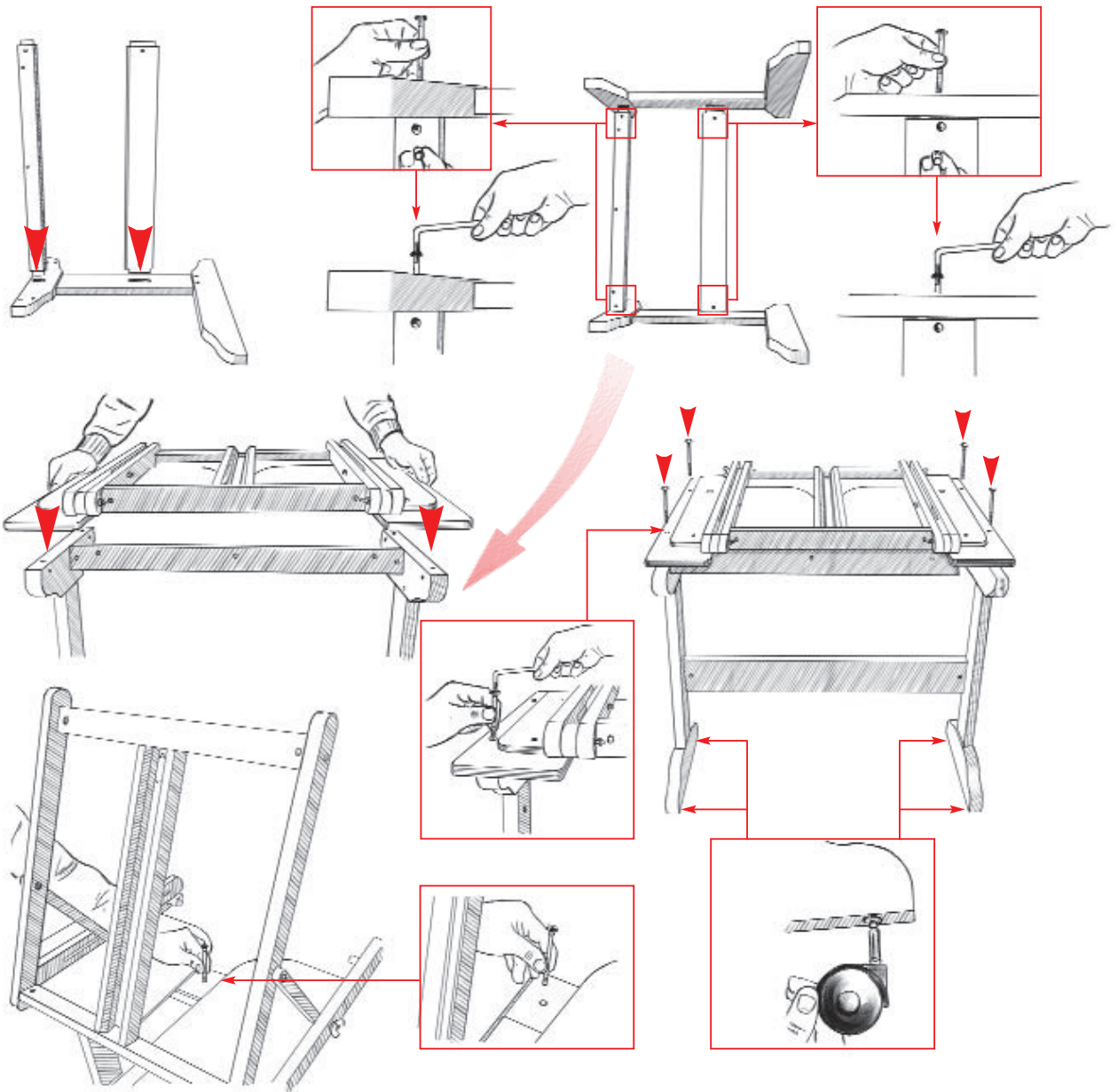

© MABEF 2009

Tutti i diritti riservati.

È vietata la riproduzione o l'adattamento anche parziale - con qualsiasi mezzo comprese le copie fotostatiche - la memorizzazione elettronica, l'utilizzo delle immagini di questo stampato senza esplicita autorizzazione.

© MABEF 2009

All rights reserved.

No part of this publication may be reproduced or used in any form or by any means - graphic, electronic, or mechanical including photocopying - without prior permission.

